

# A DIRECT DRIVE TO SUSTAINABLE WIND ENERGY

The success—or failure—of producing the most cost-effective turbines will have a direct impact on the future shape of the wind industry. Here's an overview.

By Andrew Tan

Andrew Tan is head of corporate relations for Zenergy Power. Go to [www.zenergypower.com](http://www.zenergypower.com).

**EARLY LAST YEAR** the European Wind Energy Association (EWEA) produced one of the most valuable tools for mapping out what are likely to be the dominant commercial trends in the global wind industry over the coming years. In its 156-page report “The Economics of Wind Energy,” EWEA set out to build a holistic financial framework within which the economic factors governing the commercial success of wind energy projects can be identified. Furthermore, the research ranks individual economic factors in terms of their marginal impact on the overall cost of producing wind energy over the lifetime of any wind project. In doing so the EWEA analysis spells out not only the most important considerations that wind project developers face and the factors

most strongly impacting their commercial decisions, but also the medium- to long-term consequences for innovation and technology development within the industry's entire supply chain.

Foremost on the EWEA list is the total number of full load hours (FLHs) accumulated by installed wind turbines over the lifetime of a project. The importance of this is revealed by the fact that a 90-percent increase in FLHs results in an approximate halving of energy production costs. Then there is the cost of financing. Advocates of replacing the UK's current market driven return-on-capital system with a fixed feed-in tariff—with the aim of increasing the financial attractiveness of UK wind energy investment—should take a well-deserved bow, and once again point to the



far greater rate of renewable energy deployment experienced in Spain and Germany.

At its most basic the FLH issue boils down to the simple fact that the more hours a turbine runs at its maximum rated power level, the more electricity it will produce each year and the lower the unit cost of production becomes. Unlike thermal power, the marginal cost of energy production for installed wind turbines is zero. Borrowing a phrase from real estate agents, the crucial thing about achieving maximum load hours is location, location, location. On average, onshore sites achieve around 2,000-2,500 FLHs a year, compared with an average 4,000 FLHs for offshore sites. Such a divergence in output means deployment of turbines will be given

priority to offshore locations. In fact, EWEA forecasts that the percentage of turbine investment in offshore sites will rise from 25 percent in 2015 to about 60 percent by 2030.

Now consider the economic benefits of installing larger rated turbines. For example, the average cost of electricity production at a coastal site has decreased from approximately €0.09/kWh for a 95kW rated turbine to approximately €0.05/kWh for a 2 MW turbine. Put simply, the larger the rating of your electricity generator the proportionally smaller your infrastructure costs become per installed MW. Look no further than the release by REpower and Multibrid of 5 MW turbines or Clipper Wind's ambitious development of a 10 MW turbine to see the trend set in motion by this economic reality.

Inevitably the success (or failure) of producing the most cost-effective wind turbines for the offshore industry will have a direct impact on the future shape of the wind industry as a whole. As wind power developers seek higher rates of return from their offshore locations by deploying ever-higher rated turbines, the one factor that will scuttle this aspiration is reliability. Reliability in the offshore market is of critical importance to developers as the time to repair turbines can be greatly extended by harsh weather conditions that restrict accessibility for maintenance work, thereby increasing downtime in periods of strong winds typically associated with the best power generation conditions.

Overall reliability of wind turbines comes from a huge range of factors such as operations and maintenance procedures, monitoring equipment, use of new materials, better control systems and experience (the learning rate within the industry currently sees between a 9-17 percent reduction in cost for every doubling of installed capacity). These numerous factors are driving a multitude of innovations and to date extraordinary progress is being made in many areas of wind turbine components.

But the issue that continues to afflict the industry is the reliability of the drive train. Put simply, one of the major challenges in producing wind energy is taking power captured by slow spinning blades (rotating at between 15 -24 rpm) and turning it into usable electricity using a high-speed generators (rotating at between 1,500 and 3,000 rpm).

### MECHANICAL APPROACH

To date, the industry has relied on a traditional mechanical engineering approach to this problem—namely the use of gearboxes. Reliability issues with wind turbine gearboxes is common knowledge (a quick look at the provisions on the balance sheets of some of the major gearbox manufacturers highlights this) and stems from the extreme engineering challenges that gearbox

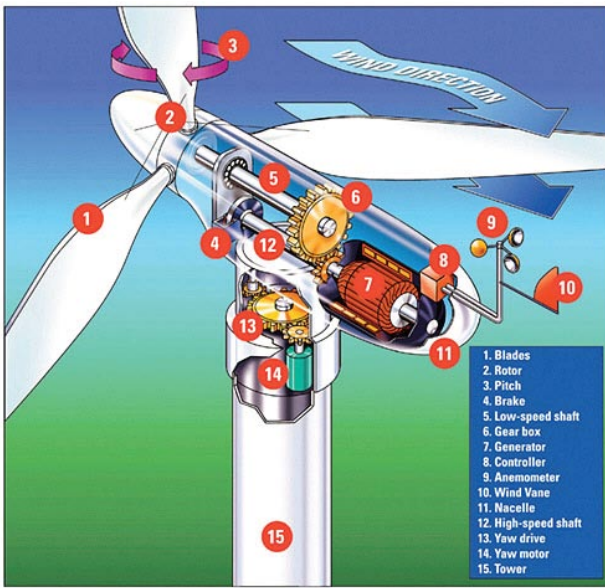

Fig. 1: Schematic of conventional wind turbine.

technology faces in wind applications. The most common approach is to use a three-stage gearbox with a high gear ratio (i.e. 97:1). Operating large complex gearboxes in wind turbines is causing a number of difficulties for both developers and turbine manufacturers and it is very difficult to see from where significant improvements in gearbox technology can come. The issues surrounding gear wearing (leading to failure and downtime), handling of multi-directional forces (turbine blades tend to flex in multiple directions as they pass the wind shadow of the turbine tower), need for replacement of large quantities of oil (an increasing concern in environmentally sensitive areas such as offshore), and component weight (the Winergy three-stage gearbox used in REpower's 5M machine weighs 63 tonnes) are hitting very serious limitations and any real improvements are hard to envisage in what is an old and matured technology. These problems are increasing as the industry moves towards larger more powerful turbines and already there has been a shift away from traditional high-speed copper generators.

### INTERIM MEASURE

Looking more closely at some of the latest turbine designs to come to market, wind farm developers will see a common trend quietly emerging that speaks volumes about concerns that manufacturers have about the reliability of gearboxes and the overall drive train. After all, why fix something that isn't broken? And that trend has been to replace traditional high-speed copper generators in favor of lower-speed permanent magnet (PM) generators. The financial edge achieved by employing slow-turning PM generators is that it enables the use of simpler gearboxes which provide more reliability, require less down time and generate more FLHs. One example of this trend is the latest 3 MW machine from Vestas. Named the V112 and succeeding the 3 MW V90, the latest Vestas machine has a PM generator in place of the high-speed copper machine used in its (same rated) predecessor. Then there is most recent 3 MW machine from Win-Wind which also uses a PM generator. Or the 5 MW Multibrid

machine produced exclusively for offshore deployment, also powered by a PM generator. Or Clipper Wind's evolving "Quantum" drive, powered by no less than 4 PM generators. Although the list continues to grow, PM generators offer a limited solution and cannot be considered as a long-term solution to reliability due to problems surrounding the weight of the machines, their degrading performance, difficulty in handling sizable permanent magnets and of course the increasingly-restricted supply of rare earth materials from China.

### ELECTRICAL APPROACH

Luckily there is another more sophisticated approach to the problem of slow spinning blades and high-speed generators, and that is to take an electrical engineering approach to the problem as opposed to the mechanical engineers' dependence on clunky, unreliable gearboxes. The outcome here is the use of multi-pole "direct" drive generators. Put simply, these generators are able to produce electricity while spinning at the same low speed of the wind turbine blades. And this is achieved by adding into the generator more electrical "poles," or copper coils. These extra poles enable the machine to generate torque at low speeds and efficiently convert the slow movement of the turbine blades into useable electricity. This eliminates the need for a gearbox and ultimately creates a far simpler (in mechanical terms) design with far fewer parts moving at far slower speeds.

This approach has already been put to good use by German turbine manufacturer Enercon, which has produced the most reliable, but not necessarily the cheapest, direct-drive wind turbines on the market. In view of the economic impact of FLHs, the financial aspects of "cheap" requires further consideration. Further to Enercon's success, the attraction of the direct-drive approach recently received another significant endorsement when

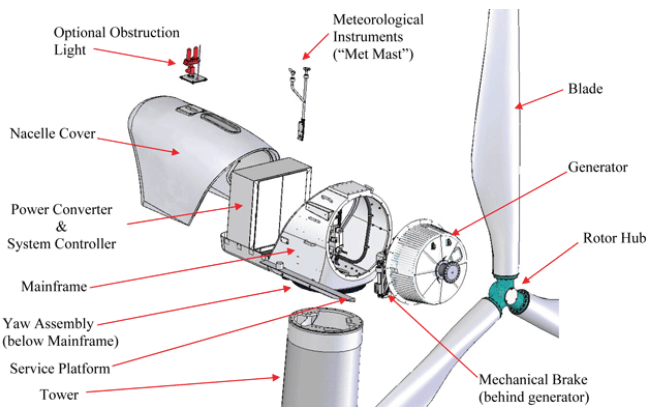

Fig. 2: Schematic of direct drive turbine.

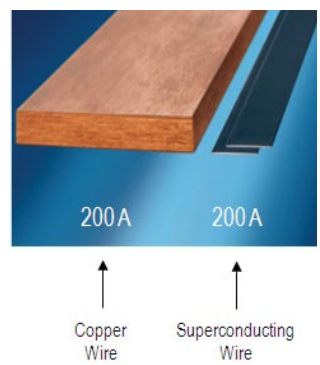

Fig. 3: Copper vs. superconductor.

GE acquired the Norwegian direct drive turbine manufacturer Scanwind as part of its well-publicized bid to improve its presence in the offshore market.

So it is safe to say that wind turbines powered by direct-drive generators with no gearbox requirements are going to play a major role in improving overall turbine reliability and financial return for wind developers. But even within this technology, there is a limitation.

Owing to the additional copper poles used to generate the torque at low speeds, direct-drive generators are very heavy.

Furthermore, the weight of direct-drive generators increases rapidly with increases in electrical rating. For example the direct-drive generator used in Enercon's 6 MW turbine weighs in the region of 450 tonnes and the company has since focused on producing 2 MW and 3 MW turbines for the onshore industry. At 450 tonnes, problems rapidly develop with transportation and installation, particularly with the availability of lifting ships capable of deploying such weights in an offshore environment. Day rates for such specialized offshore vessels are substantial and can lead to dramatic increases in offshore wind project installation costs.

### SUPERCONDUCTORS

The wind industry has come up against some very harsh technical limitations where gains on one front (reliability) are offset by losses on another (restriction on size). In situations like these, real breakthroughs in technology are needed, and in the case of wind industry generators this may come from a set of materials called superconductors.

At their simplest level, superconductors conduct electricity with no electrical resistance and, as well as being 100-percent efficient (no heat losses from resistance to electron flow), they can carry more than one hundred times the amount of electricity than copper wires. Or put another way, you need only one hundredth the material for any given electrical application. As a result, they can be used to replace the bulky copper poles found in direct-drive generators to bring about substantial weight reductions that produce a radically different financial equation for direct-drive turbines. In doing this, manufacturers can produce direct-drive generators (high reliability) that are approximately one sixth the weight of copper-based machines (enabling the use of high rated equipment).

Encouraging work has already been carried out producing a new class of generators that can break through the restrictions of traditional technology. By next February German utility E.On will become the first power producer to put a superconductor-based generator into commercial use. Built by Convertteam SAS using superconductor technology from AIM-quoted Zenergy Power, the generator is expected to herald the development of an important new technology sector for power generation. In addition to the E.On project, Convertteam and Zenergy Power are also building a 10 MW class direct-drive superconductor generator that will weigh 80 tonnes compared to the 450-tonne weight of a copper-based 6 MW machine.

If successful, the use of superconductors in generators is thought to have the potential to reduce offshore wind power costs by 25 percent simply by the reducing the amount of steel in the turbine tower and the amount of concrete poured into the foundations of the unit. Cheaper transportation and shipping costs will also play a major factor in cutting wind farm development costs. Significantly, given the extensive research already carried out and the emergence of working demonstration models, it may just be a matter of years before the financially-attractive role played by superconducting technology in producing large-scale offshore wind power becomes obvious to everyone. 🌪